

Technical Specification

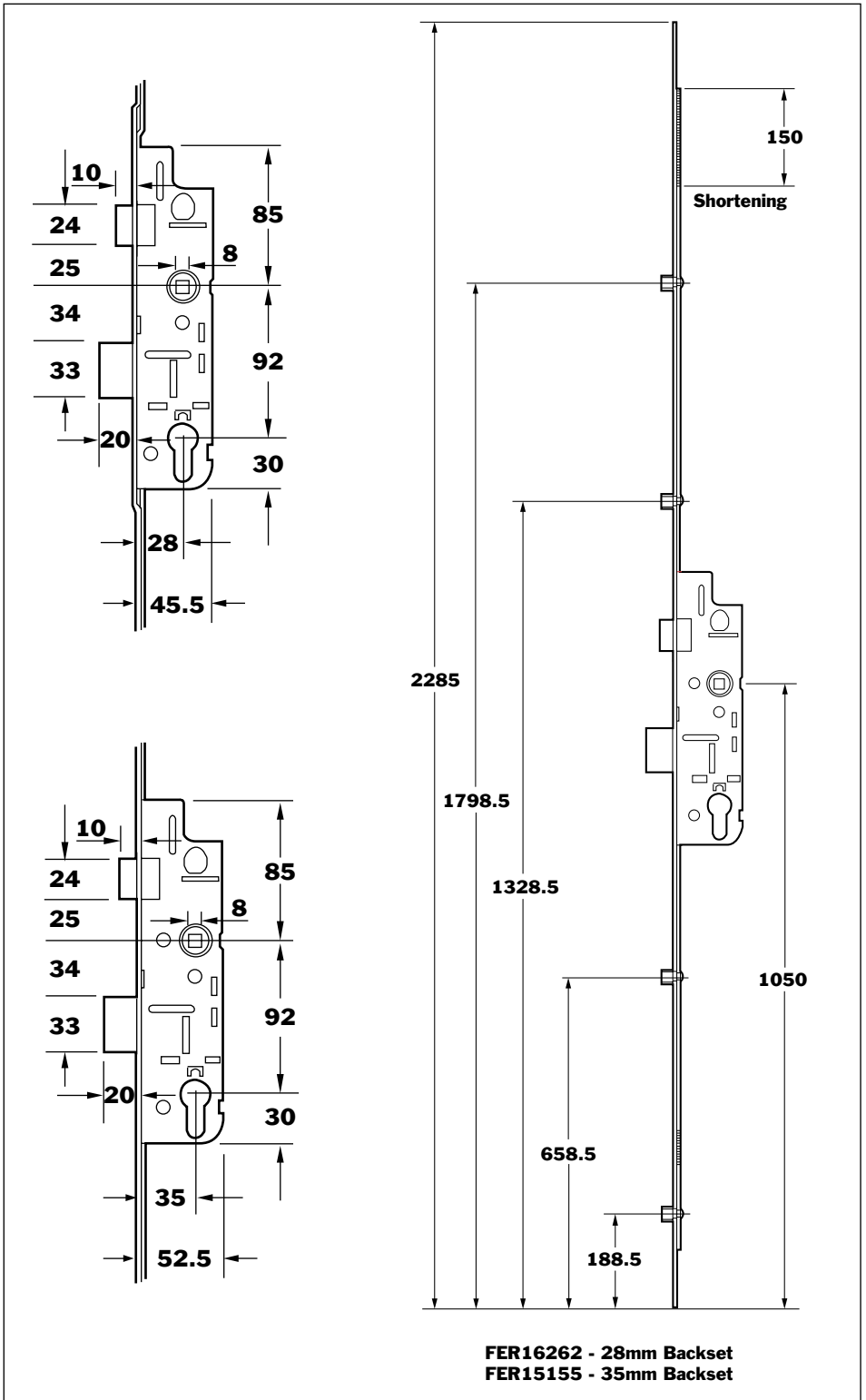

Manufactured to ISO 9001 Standard.

Doorbolts are manufactured from high quality steel and die-cast zamak components.

The visible surfaces are yellow bichromated to withstand in excess of 240 hours salt spray testing.

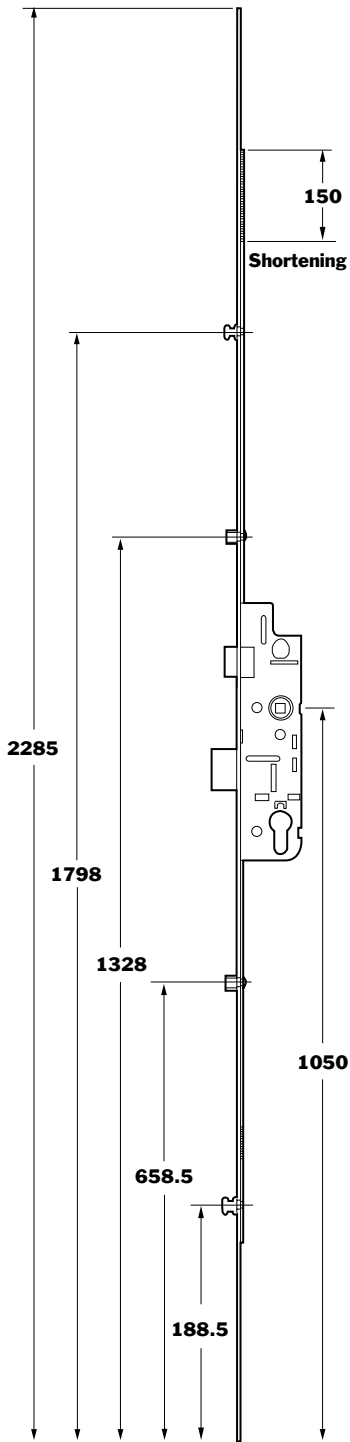

FER18354 - 28mm Backset
FER18353 - 35mm Backset

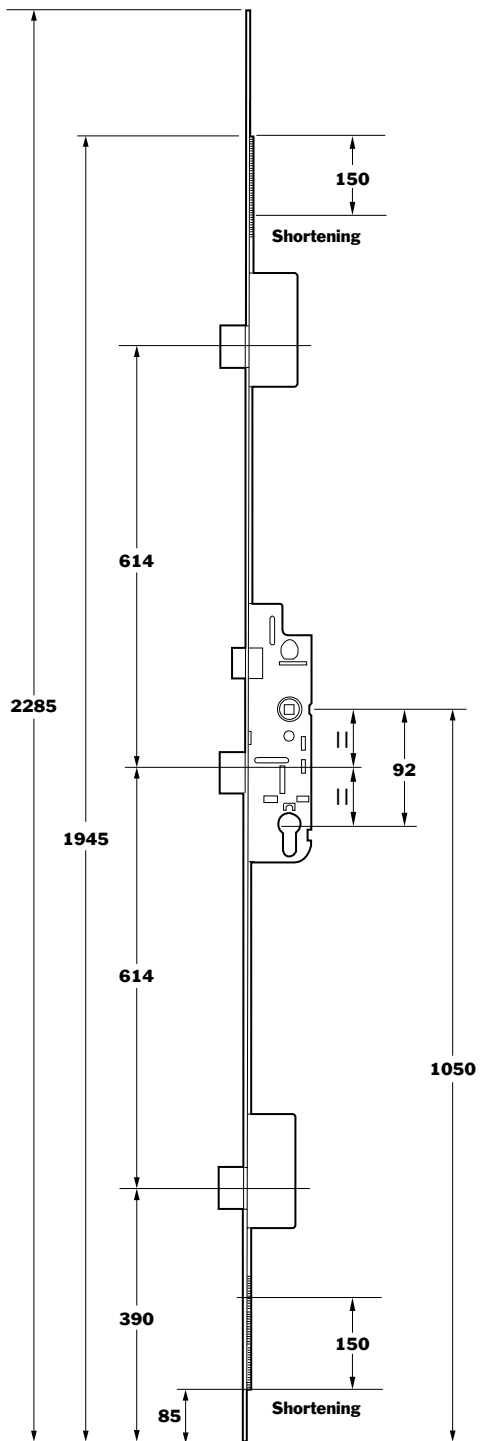

FER16266 - 28mm Backset
FER15326 - 35mm Backset

Technical Specification

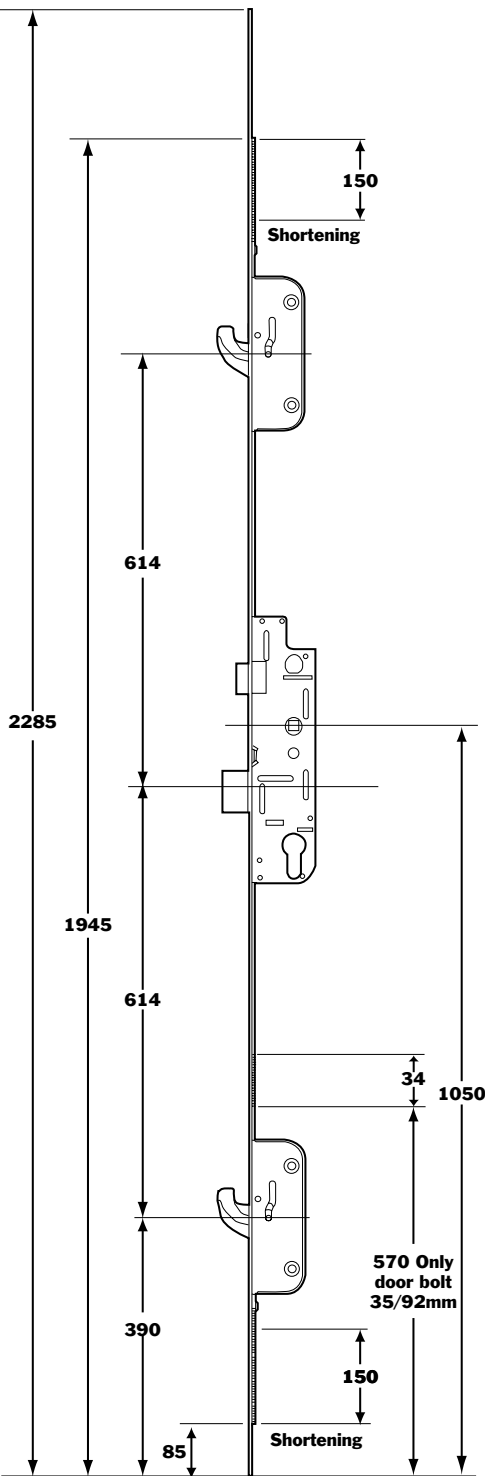

FER18347 - 28mm Backset
FER18342 - 35mm Backset
FER19398 - 35mm Backset

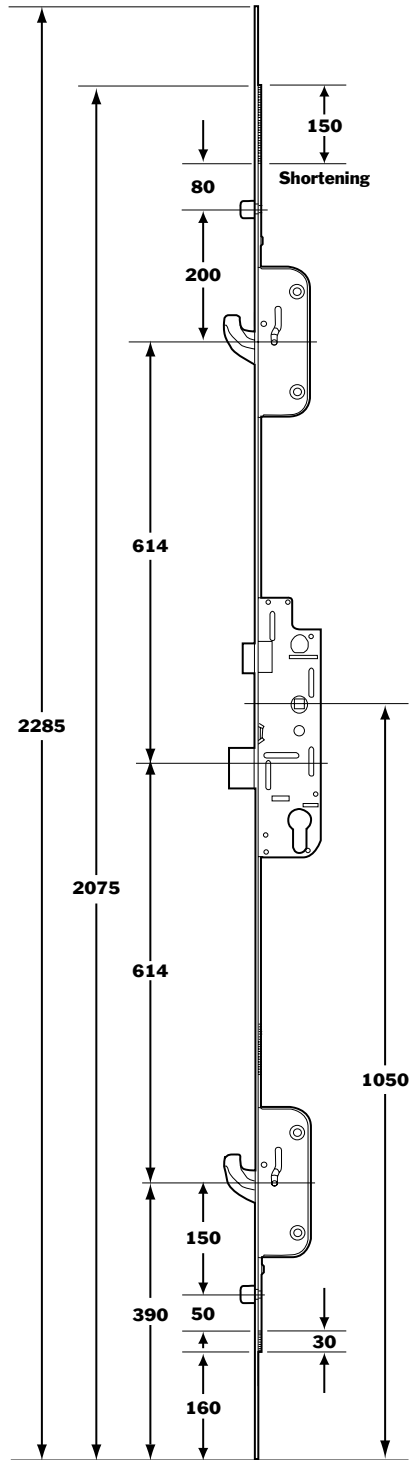

FER19756 - 35mm Backset
FER19757 - 35mm Backset