

Technical Specification

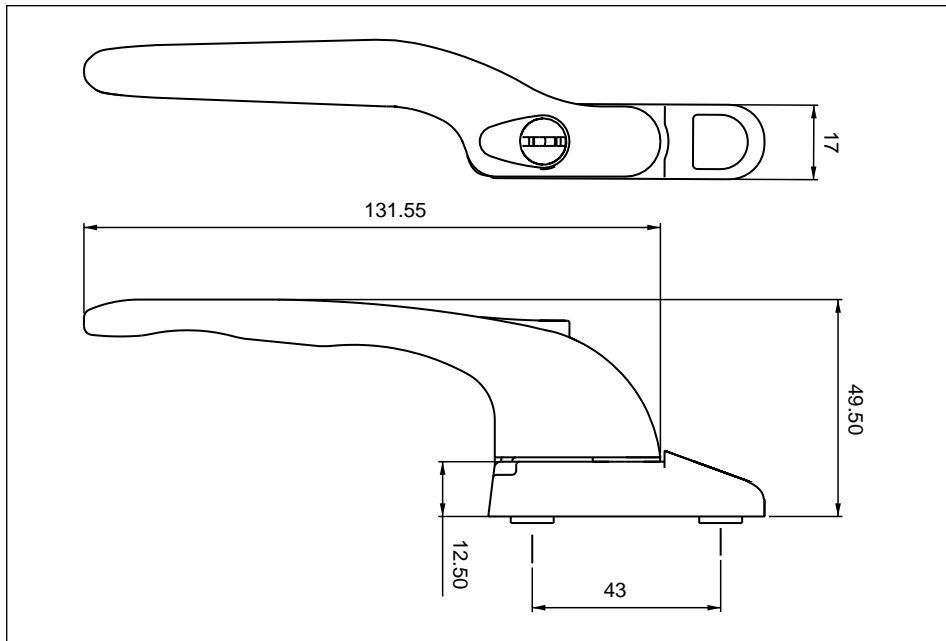

Zinc Alloy:

ZA3 – Excellent tensile strength, ductility and impact resistance; high dimensional stability, easily accepts plating and finishes.

Powder Coating:

SYNTHA PULVIN PLUS – Part of a totally controlled super-durable polyester powder colouring process, guaranteed for 25 years. Designed to decorate and protect metallic substances exposed to extreme climatic conditions, offering excellent gloss retention whilst meeting the requirements of BS6496 and BS6497.

Electroferretic Lacquer:

CLEAR LCX CF (highly enhanced UV resistance) and LCX INTERPAS (improved corrosion protection for Brass and Zinc).